

पुणे
स्मार्ट सिटी
डेव्हलपमेंट
कॉर्पोरेशन लिमिटेड



PUNE
SMART CITY
DEVELOPMENT
CORPORATION LTD.

Expression of Interest

for

“Selection of System Integrator for
Design and Implementation of Low-Power Wireless
Communication Network Infrastructure for Pune Smart
City Services”

EoI Notification No.: PSCDCL/LPWCN/29/2018

Issued By:

CEO

Pune Smart City Development Corporation Limited

Dated: 28th Sep. 2018

Table of Contents

Notice Inviting Expression of Interest	5
1. Disclaimer	7
2. Introduction and Background	9
2.1 About Pune	9
2.2 About Pune Smart City	10
2.3 About Pune Municipal Corporation (PMC)	11
2.4 About Low-Power Wireless Communication Network Infrastructure Project ..	12
2.5 Objectives of Low-Power Wireless Communication Network Infrastructure Project	12
3. EoI Process and Issuance of RFP	14
4. Scope of Work	15
4.1 Indicative Scope of Work for System Integrator for Low-Power Wireless Communication Network solution:	15
4.2 Operations & Maintenance for 5 years:.....	17
4.3 Indicative Functional Architecture Overview:	18
4.4 Proof of Concept (PoC)	18
4.4.1. Obligations of PSCDCL during the PoC period	19
4.4.2. Obligations of selected agency during the PoC.....	19
5. General Information	20
5.1 Eligible Applicants	20
5.2 Experience:	20
5.3 Non-black listing:	20
6. Instructions to Applicants	22
6.1 Concept Note:	22
6.2 Availing EoI Documents.....	23
6.3 Completeness of the EoI Response	23
6.4 EoI Preparation Cost	23
6.5 Sealing, marking and submission of EoI.....	24
6.6 Late Submission of Proposal for EoI.....	25
6.7 Language of Bids.....	25
6.8 Evaluation of EoI	26
6.9 Key Suggestions	26

6.10	No obligation to issue of RFP	26
6.11	Right to cancel the EoI Process	26
6.12	Proposed Timelines	28
7.	Specific formats for the Applicants to fill in the details	29
7.1	Format A_1: Cover Letter	29
7.2	Format A_2: Details of Applicant	32
7.3	Format A_3: Details of relevant experience	35
7.4	Format A_4: Concept Note	37
7.5	Format A_5: Declaration – No Blacklisting.....	38
7.6	Format A_6: Power of Attorney for Signing the EoI:	40

Glossary

PMC	Pune Municipal Corporation
EoI	Expression of Interest
GPS	Global Positioning System
GoI	Government of India
GoM	Government of Maharashtra
IT	Information Technology
O&M	Operation & Maintenance
PSCDCL	Pune Smart City Development Corporation Limited
SCOC	Smart City Operations Centre
COTS	Commercial off-the-shelf
SI	System Integrator
BOM	Bill of material
KPI	Key performance indicators
MoUD	Ministry of urban development
FIRM	Firm means any entity such as Private Limited company/ Public Limited company/ LLP/ Partnership/ HUF/ Foreign Incorporated Entity

Notice Inviting Expression of Interest for

“Selection of System Integrator for Design and Implementation of Low-Power Wireless Communication Network Infrastructure for Pune Smart City Services”

[PSCDCL / LPWCN / 29]

This EoI Document is being published by the Pune Smart City Development Corporation Limited (PSCDCL) for the project of “Low-Power Wireless Communication Network Infrastructure” which is an initiative to establish a pan-city highly secure wireless network that will support the low bandwidth & low-powered internet-of-things (IoT) devices to build the digital infrastructure across the city that will accelerate the implementation of various Smart City & PMC initiatives like Smart Healthcare, Smart Mobility, Smart Solid Waste Management etc..

PSCDCL is proposing to select a private sector partner / System Integrator to procure, supply and implementation of the Low-power Wireless Communication Network connectivity.

The purpose of this EoI Document is to provide interested parties with the relevant information regarding the project and understand the scope of the Project and invite feedback from interested private sector Applicants. The Applicants are advised to study this EoI Document carefully before submitting their feedback & suggestions in response to the EoI Notice. The feedback & suggestions received as part of the response from the industry participants to this EoI Document may or may not be used towards formalizing the RFP for the Project which is proposed to be released in the near future. This EoI document is not transferable. No pre-qualification of Applicants is proposed to be done as part of this EoI.

Last date (deadline) for EoI response	Feedback & suggestions in response to the EoI, should be submitted through: a. Email to: projects@punsmartcity.in Latest by 22/10/2018 up to 15:00 hrs. b. Hard copy of the responses (duly signed) through Speed Post or Courier or in person. Latest by 22/10/2018 up to 15:00 hrs. at the following address: CEO PSCDCL
--	--

	A-204, ICC Trade Towers, Pune - 411016 Senapati Bapat Marg Pune
Pre-EoI Meeting date	9 th Oct. 2018, 15:00 hrs. at <u>ICC Trade Towers, S.B. Road, Pune</u>
Website to download EoI	https://pmc.gov.in https://punsmartcity.in

The right to accept/reject any or all the responses received is reserved with PSCDCL without assigning any reason thereof.

Pune Smart City Development Corporation Limited

1.Disclaimer

This Expression of Interest (EoI) contains brief information about the Project and will assist PSCDCL to formulate the RFP for the process of selecting the Applicants during the RFP stage. This EoI is not an agreement or an offer by the purchaser/authority to the applicants or any other person.

The purpose of the document is to provide the applicants with information to assist the formulation of their EoI application or response to EoI Document (“the Application”).

The information provided in this EoI Document, to the Applicants is on a wide range of matters, some of which depends upon interpretation of law. The Applicants may conduct their own independent assessment, site visit, investigations and analysis and check the reliability, accuracy and completeness of the information at their end and obtain independent advice from relevant sources as required before submission of their EoI application.

Furthermore, the information provided in this EOI Document is not intended to be an exhaustive account of statutory or commercial requirements and should not be regarded as a complete or authoritative statement of law. PSCDCL along with its directors, associates, employees, affiliates, consultants makes no representation or warranty and shall have no liability to any person including the Applicant under any law, statute or by any rule and/or regulation made thereunder, tort, equity, principles of restitution, unjust enrichment or otherwise for any loss, damage, costs or expenses which may arise from or be incurred or suffered on account of anything contained in this EOI Document or otherwise, including the accuracy, adequacy, correctness, reliability or completeness of the EOI Document any assessment, assumption, statement or information contained therein or deemed to form part of this EOI Document or arising in anyway in this subject.

Pune Smart City Development Corporation Limited (PSCDCL) or any of its employees or advisors / representatives shall incur no liability under any law, statute, rules or regulations as to the accuracy or completeness of the EoI Document. PSCDCL reserves the right to change any or all conditions/ information set in this EoI Document by way of revision, deletion, updation or annulment through issuance of appropriate addendum as the organisation may deem fit without assigning any reason thereof.

PSCDCL will not entertain or be liable for any claim for costs and expenses in relation to the preparation of the EoI applications to be submitted in terms of this EoI Document.

The information contained in this EoI Document or subsequently provided to the prospective Applicants, whether verbally or in documentary or any other form by or on behalf of PSCDCL or any of its employees or advisers, shall be considered confidential and is not to be reproduced/ adopted/ displayed for any purpose whatsoever.

This EOI Document is for informative purpose only and does not imply that PSCDCL is bound to select or short list pre-qualified applications for the RFP stage or to appoint the Applicant for the Project as the case maybe and PSCDCL further reserves its absolute right and discretion to terminate the process at any time without assigning any reasons or explanations thereof.

2. Introduction and Background

2.1 About Pune

Pune is the seventh-most populous city in India and the second largest in the state of Maharashtra. It was known as Punya Nagari in earlier times. It is situated 560 meters (1,837 feet) above sea level on the Deccan plateau, on the right bank of the Mutha River. Pune city is the administrative headquarters of Pune district and was once the center of power of the Maratha Empire.

Further, the city is also known for manufacturing and automobiles, as well as government and private sector research institutes for information technology (IT) education, management and training that attract migrants, students, and professionals from India, South East Asia, the Middle East, and Africa.

Pune is also one of the fastest growing cities in the Asia-Pacific region. Pune is considered as the cultural capital of Maharashtra and is also popularly known as ‘Queen of the Deccan’. Pune is also known as ‘Oxford of the East’ and has one of the oldest universities and colleges in India such as, University of Pune, College of Engineering Pune and Fergusson College.

Pune is one of India’s major industrial hubs. The city is known for its automobile and Information Technology (IT) industries. Other major manufacturing sectors in Pune are steel, equipment, biotechnology and pharmaceutical. Pune is one of the most populous districts in Maharashtra and ranks third in the state in terms of population.

2.2 About Pune Smart City

The Pune Smart City proposal was selected for priority financing under Smart City Mission by Ministry of Urban Development (MoUD), Government of India. Thereafter, the Pune Municipal Corporation (PMC) has incorporated a Special Purpose Vehicle (SPV) company called PUNE Smart City Development Corporation Limited (PSCDCL), under the Companies Act 2013, solely for the purpose of implementing the Smart City proposal. PSCDCL is fully owned by the Government with equal shareholding from the Government of Maharashtra and the Pune Municipal Corporation (PMC).

The Board of PSCDCL is chaired by Principal Secretary, Urban Development Department, Government of Maharashtra with board comprising of elected representatives of PMC, representatives of the State and Central Government as well as independent directors

PSCDCL has received the funding from Government of India and PMC/ the State Government for implementing the smart city projects. Given the wide range of technical and sector specific expertise required to implement the smart city projects, PSCDCL shall be supported by a team of consultants for strategic, technical and project management support.

2.3 About Pune Municipal Corporation (PMC)

The Pune Municipal Corporation (PMC) was established on 15 February 1950. The PMC is in charge of the civic needs and infrastructure of the metropolis. Pune is divided into 15 municipal wards and about 76 electoral wards/prabhags.

Since 1950, the Pune Municipal Corporation is administrating the city and serving citizens. Pune Municipal Corporation has taken an initiative for implementing e-Governance. Success of e-governance depends on use of Information Technology in mobilization of Government resources and utilization of these scarce resources with an aim of providing a better service.

Pune Municipal Corporation stood second in the Smart Cities Challenge launched by Ministry of Urban Development, Govt. of India. Under Smart City Initiative, PMC committed for making governance citizen-friendly and cost effective by delivering services electronically to ensure accountability and transparency, especially using mobiles to reduce cost of services and providing services to its stakeholders without having to go to municipal offices; and by facilitating e-groups to listen to citizens and obtain feedback and use online monitoring of programs and activities with the aid of cyber tour of worksites.

2.4 About Low-Power Wireless Communication Network Infrastructure Project

PSCDCL is engaged in the development of various Smart City projects across sectors in the city. With the implementation of projects' like Network of Smart Elements, PSCDCL in collaboration with PMC departments has set-up the network of smart sensors which are integrated with the centralized Command and Control Centre and facilitate the city departments with real-time information and aids in decision making.

Since it was understood, that the deployment of network connectivity was the deciding factor for the smart sensors to communicate and meet the desired outcome, on the similar lines, the need for establishing the wireless network connectivity arise that will support the low bandwidth & low powered IoT devices to accelerate the implementation of various Smart City & PMC initiatives like Smart Healthcare, Smart Mobility, Smart Solid Waste Management etc.

Through this project, PSCDCL intends to engage a System Integrator to design and implement the Low-Power Wireless Communication Network Infrastructure to promote Smart City & PMC initiatives.

With a vision to expand the digital services across the city, PSCDCL now proposes to develop the cost-effective Low-Power Wireless Communication Network infrastructure for the city which will support low-bandwidth device-to-device communication.

2.5 Objectives of Low-Power Wireless Communication Network Infrastructure Project

The aim for setting-up the Low-Power Wireless Communication network infrastructure is to build the cost-effective solution for the city that will connect all the IoT devices (low-bandwidth & low-powered) which are currently being implemented through various Smart City initiatives. With the expansion of digital technologies, PSCDCL foresees this potential infrastructure will drive - Smart mobility, Smart Energy, Smart buildings, Smart Waste Management, Smart Water Management, Smart Healthcare, Smart Parking, Smart Infrastructure and security for the city.

Besides providing the pan-city coverage, PSCDCL aims to market this solution to various industry players that will enable them to use this network as a plug and play infrastructure to set-up their specific industrial use-cases.

The key objectives of this project are the following:

1. Enterprise-ready IoT enabled low-power & low-bandwidth wireless network & platform that can help PMC / PSCDCL in elevating the businesses to new level
2. Reliable and secure plug & play infrastructure for the industry players to promote their specific industrial use-cases
3. Faster roll-out of digital services for the city
4. Optimum Monetization of assets

3.EoI Process and Issuance of RFP

During the stage of Expression of Interest (EoI) is undertaken as an industry consultation where, credible Applicants having requisite capability for undertaking the Scope of Work have been requested to provide their inputs on the key parameters to be adopted by PSCDCL as it determines the terms and conditions of the RFP. Pre-qualification of Applicants will not be done at this stage.

Subsequent to this EoI and the finalization of the Project details, PSCDCL proposes to issue a Request for Proposal (RFP) for selection of interested Applicants for the deployment of the Project.

PSCDCL does not, in any manner whatsoever, warrant or represent that it will subsequently proceed to release the RFP and/or initiate the RFP Stage of the Bidding Process. Accordingly, the information regarding the RFP made in this EOI are indicative in nature and purely informative, and non-binding.

PSCDCL in its absolute discretion may cancel, change, alter or replace the RFP Stage of the Bidding Process and/or the Project itself, without according any reason thereof or providing any prior notice to any person including the Applicants.

4. Scope of Work

4.1 Indicative Scope of Work for System Integrator for Low-Power Wireless Communication Network solution:

The project emphasizes to develop the cost-effective low-power & low-bandwidth wireless communication network infrastructure solution to connect all the network of devices which are being implemented by the city through various initiatives under Smart City Plan.

This will be done in phases with first phase including setting-up of the low-power wireless communication infrastructure solution for IoT sensors which are being implemented through various PMC initiatives like 24x7 water project (pressure sensors, smart meters), Solid waste management (Smart bins sensors), Vehicle Tracking solution (1200 + GPS devices) etc. for ABB (Aundh-Baner-Balewadi) area. The deployed Low-Power Wireless connectivity network should support these sensor devices type and the communication protocol that governs the data flow exchange between computing systems.

Later, the project phases will include to establish Low-power wireless communication infrastructure for IoT sensors which are planned to be implemented through future IoT / Digital Infrastructure projects by PSCDCL, PMC, PMPML, Police for Projects including but not limited to like ITMS, E-connectivity, Wireless Surveillance Cameras, Electric Vehicles etc.

The details below cover the proposed scope of work for the SI to be engaged. The scope will be fully elaborated during the RFP stage:

1. Baseline assessment of the existing network deployed by PSCDCL / PMC through various ICT initiatives. After assessment, SI should propose the low-power network connectivity requirements for the Pune city.
2. Define Low Power Wireless Network Connectivity Infrastructure components and architecture for the proposed solution.

3. Design and implement the low-power wireless network connectivity solution with the following capabilities:
 - a. Low latency
 - b. Robust & Scalable Architecture
 - c. Network security and privacy
 - d. Self-healing abilities
 - e. Wide-area coverage
 - f. Ability to work with other network standards like IP, TCP, HTTP, UDP and other web sockets
 - g. Compatibility with market technologies like Cellular networks (3G/4G), Bluetooth and other Low-power solution available in the market etc.
 - h. Support Extensive use-cases
(Smart Parking, Utility meters, Smart Mobility, Solid Waste Management etc.)
 - i. Reliability (99.999%)
 - j. Uniform experience for all the connected devices

4. Design, configure, customize and deploy centralized Device Management Platform that will connect various IoT devices over the Low-Power Wireless Communication Network (LPWCN) and will have the following capabilities:
 - a. Support management protocols
 - b. Support different device classes
 - c. Network & device Monitoring
 - d. External system integration
 - e. Flexibility to configure any device model
 - f. Fault monitoring
 - g. Automatic classification
 - h. Clustering and load balancing
 - i. Vulnerable to any Security threat
 - j. Uniform experience for all the connected devices
 - k. Real-time tracking
 - l. Alerts & Notifications
 - m. Dashboards

5. Asses, procure and deploy the hardware & software components, required for deployment of Low-Power Wireless Connectivity solution. This will include but not limited to RF devices, Concentrators / Gateways / end-point communication devices, network servers etc. SI should preferably propose Low-Power Wireless Connectivity Network compliant COTS sensor nodes and gateways. All the equipment proposed to be supplied under this project should be approved by the relevant local / central Govt. authorities for use in India.
6. Leverage the Smart City Operations Centre (SCOC) for Command and Control Center and integration with SCOC platform to run the device management operations.
7. Propose monetization options & business case for PSCDCL for the established Low Power Wireless Connectivity network solution to market various business opportunities and industry use-cases.

4.2 Operations & Maintenance for 5 years:

1. System Integrator shall provide full operational, maintenance and technical support (on-site support) during the entire period of the contract post Go-Live.
2. System Integrator shall be responsible for managing and monitoring the complete architecture of the Low Power Wireless Communication Network including all hardware as well as software components during the entire period of contract.
3. All the solution components shall be managed through a centralized management software. User credentials for MIS access to the software must be shared by SI with PSCDCL.
4. During the duration of the contract, the SI shall be required to conduct periodic checks of the deployed solution for performance, scalability, security, and further perform continuous monitoring of operations on behalf of PSCDCL. The SI shall be required to provide necessary information, support and MIS reports in the desired format to the PSCDCL and/or any of its authorized representatives to carry out forensic analysis at any point during the contract, if required.
5. The System Integrator will have to provide necessary trainings to the departmental staff identified by PSCDCL from time to time on usage of the system.

4.3 Indicative Functional Architecture Overview:

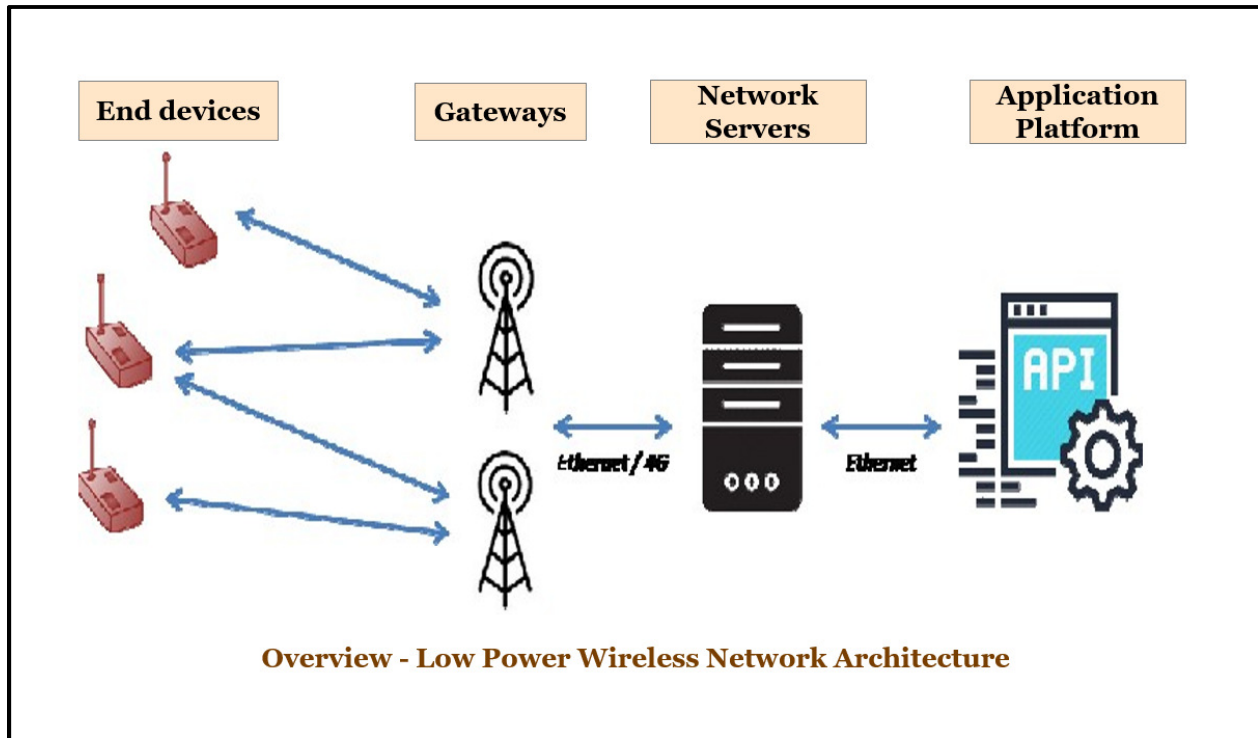

4.4 Proof of Concept (PoC)

PSCDCL may ask the selected agency to deploy the Low-Power Wireless Connectivity Network Infrastructure solution on trial basis for duration of 3-6 months for the selected 15-20 sensors (SWM department / Water department or any other department) without any cost liability to PSCDCL/PMC.

Report on the following criteria will have to be submitted at the end of the trial run.

- a) Performance – latency report and other relevant test reports
- b) Monitoring of deployed network solution – as per listed requirements, MIS reports
- c) Ease of operations – based on user feedback (department, registered vendors or other stake holders)

It will be responsibility of the SI to manage the supply, installation, testing, commissioning of proposed solution at its own cost and risk during the PoC period. The exact dates for the PoC will be communicated separately.

4.4.1. Obligations of PSCDCL during the PoC period

- a) Provide access to infrastructure for PoC scope and issue necessary permissions
- b) Operate the systems including allocating support staff for the operations
- c) Approve design documents as applicable
- d) Provide integration details of existing equipment and IT systems
- e) Provide permission to integrate the equipment as applicable
- f) Provide power supply at trial run locations including recurring charges

4.4.2. Obligations of selected agency during the PoC

- a) Design, procure, develop, configure & implement Low-Power Wireless Connectivity network solution including required software & hardware components for 3 months
- b) Deploy the Low-Power Wireless Connectivity network solution on cloud / data center
- c) Design, deployment documentation as per PSCDCL requirements
- d) On-site training to PMC, PSCDCL staff
- e) On-site support in operations (need based)
- f) Retain data securely and handover periodically and at the end of trial run.

5. General Information

5.1 Eligible Applicants

The applicants eligible for participating in the EoI process shall be any of the following categories:

The Applicant shall be legally competent to enter into contract as per prevailing Indian law and must be either: (i) a company incorporated under the Companies act 1956 (as amended or re-enacted and restated including the Companies act 2013 as notified from time to time), (Copy of certificate of incorporation, Memorandum and Article of the Association of the Applicant should be submitted) or (ii) Partnership firm registered the Indian Partnership Act (copy of registered partnership deed should be submitted) or a (iii) registered proprietary firm (Copy of sales tax/service tax registration, EPF registration, Shop registration certificate, as may be applicable, should be submitted).

Foreign firms constituted under Applicable Law of any other country are also permitted to participate in submission (Copy of Certificate of Incorporation, Memorandum and Article of the association or constituting legal documents of the Applicant should be submitted). In case of foreign Company, incorporation documents other than English language should be accompanied by a notarized translation to English language only.

The term Applicant used hereinafter would therefore apply to both the above-mentioned categories. Any entity, which has earlier been barred by PSCDCL from participating in its projects, would not be eligible to submit an EOI individually, if such bar subsists as on the last date of submission of EoI.

5.2 Experience:

The Applicant must have experience of executing the project covering the specified scope under para 4.1.

5.3 Non-black listing:

The applicant as on date of submission of the EoI, should not be blacklisted by Central / State Governments in India / PMC.

Note:

- i. The applications must be signed by duly authorized person holding the power of attorney in case of limited company or corporation. (A certified copy of the Power of Attorney shall accompany the application).
- ii. Applicants may form a consortium/joint venture to enhance their qualification during the RFP stage.
- iii. Number of members allowed in a consortium during the RFP stage shall not exceed 3 (three). Details of this information will have to be provided at the RFP stage.
 - a) Members of the Consortium shall nominate one member as the lead member (the “Lead Member”)
 - b) The Application should include a brief description of the roles and responsibilities of individual members, particularly with reference to technical obligations;
 - c) An individual Applicant cannot at the same time be member of a Consortium applying for pre-qualification. Further, a member of a particular applicant Consortium cannot be member of any other applicant Consortium

6. Instructions to Applicants

PSCDCL invites reputed firms to submit their proposals for the Project for PSCDCL in accordance with conditions and manner prescribed in this Expression of Interest (EoI) document.

No Applicant shall submit more than one EoI.

6.1 Concept Note:

PSCDCL intends to engage the SI that shall be responsible to design, implement and maintain the solution of Low-Power Wireless Communication Network Infrastructure on a PPP model.

The participants of the EoI are required to submit a Concept Note regarding their understanding of the Project Scope and their proposal, which is in best interest of PSCDCL.

The Applicants should cover the following aspects in the Concept Note:

- Solution architecture w.r.t their understanding of the project scope
- Solution details – components, platform, operating system, database, integration platform details
- Technical architecture including deployment architecture (cloud/on-premise/hybrid)
- Approach & Methodology to implement the solution
- Proposed business model and concessionaire structure with Public Network Telecom operator / or any other interested parties.
- Functional compliance of the proposed solution
- Indicative BOM and technical specifications of the Wireless Communication Network components
- Maintenance and on-site support arrangement during operations
- Compliance with Security, scalability, manageability, performance parameters
- Proposed KPI's and acceptance criteria for the Low-Power Wireless Communication Network solution
- Connectivity requirements

- Power requirements
- Compliances & certifications as per Industry standards
- Case Studies of other client implementations of Low-Power Wireless Communication Network solution
(Specific Implementation studies w.r.t. Smart Cities applications, building and campus solution, Energy management, asset tracking and management etc.)
- Learnings from other client implementations
- Facilitation required from PSCDCL / PMC in terms of RoW, relevant permissions etc. for the deployment of proposed solution

6.2 Availing EoI Documents

The EoI Document can be downloaded from the website <https://pmc.gov.in> or <https://punsmartcity.in> up to the date and time mentioned in the EoI Notice. PSCDCL / LPWCN / 29 / 2018.

6.3 Completeness of the EoI Response

Applicants are advised to study all instructions, forms, terms, requirements and other information in the EoI documents carefully. Submission of bid shall be deemed to have been done after careful study and examination of the EoI document with full understanding of its implications. The response to this EoI should be full and complete in all respects. Failure to furnish all information required by the EoI document or submission of a proposal not substantially responsive to the EoI documents in every respect will be at the Applicant's risk and may result in rejection of their proposal.

6.4 EoI Preparation Cost

The Applicant is responsible for all costs incurred in connection with participation in this process, including, but not limited to, costs incurred in conduct of informative and other diligence activities, participation in meetings/discussions/presentations, preparation of proposal, in providing any additional information required by PSCDCL to facilitate the evaluation process. PSCDCL will in no case be responsible or liable for those costs,

regardless of the conduct or outcome of the bidding process. All materials submitted by the Applicant shall become the property of the PSCDCL and may be returned at its sole discretion.

6.5 Sealing, marking and submission of EoI

The Application should be submitted through Email and Postal (Speed Post or Courier) or in person, so as to reach on or before 22/10/2018 up to 15:00 hrs at PSCDCL office (ICC Trade Tower, SB Road, Pune). **PSCDCL won't be responsible for any postal delays.**

The Application including supporting documents and its duplicate shall be typed or written in indelible ink and the Applicant shall initial each page. All the alterations, omissions, additions, or any other amendments made to the Application shall be initialled by the Authorised Signatory of the Applicant.

Applicant should fill in information in prescribed formats for qualification as mentioned in the EoI Document.

The Applicants shall submit all supporting documents in the format as prescribed in the EoI Document along with suggested documentary evidence with the Application.

The Application shall include the following requisite documents and necessary supporting documents as specified in Appendix A to G, each envelope should contain –

- a. Cover Letter as per format A_1 (Please Refer Section 7.1);
- b. Details of Applicant as per format A_2 (Please Refer Section 7.2);
- c. Details of Relevant Experience as per format A_3 (Please Refer Section 7.3);
- d. Concept Note as per format A_4 (Please Refer Section 7.4);
- e. Declaration – No Blacklisting as per format A_5 (Please Refer Section 7.5)
- f. Power of Attorney for Signing the EoI as per format A_6 (Please Refer Section 7.6)

Applicants should submit two copies of the EoI including the information requested in the prescribed formats along with any supporting documents. The original copy shall be sealed in an envelope marked “Original” and the other copy in an envelope marked “Copy”. Both these envelopes shall then be enclosed in an

outer envelope marked “*Selection of System Integrator for Design and Implementation of Low-Power Wireless Communication Network Infrastructure for Pune Smart City Services*”. Along with the hardcopies, a soft copy in PDF format shall also be submitted through a CD / DVD / USB flash drive.

If the envelopes are not sealed and marked as instructed above, the PSCDCL assumes no responsibility for the misplacement or premature opening of the contents of the application and consequent losses, if any suffered by the Applicant.

In the event of any discrepancy between the original and CD/Pen Drive/USB stick, the original shall prevail.

The submission should be signed by an authorized person holding the power of attorney in case of limited company or corporation. A certified copy of the power of attorney shall accompany the EoI. Proposals must be direct, concise, and complete. PSCDCL will evaluate Applicant’s proposal based on its clarity and completeness of its response to the requirements of the project as outlined in this EoI. The CEO, PSCDCL reserves the right to accept or reject any or all the proposals without assigning any reason.

6.6 Late Submission of Proposal for EoI

EoI response not reaching on or before the specified time limit will not be accepted. However, PSCDCL in its absolute discretion and prerogative may allow late Applications submitted by the Applicants by according proper reasons therefore.

6.7 Language of Bids

The responses prepared by the Applicant and all correspondence and documents relating to the bids exchanged by the Applicant and PSCDCL, shall be written in English language. Any printed literature furnished by the Applicant in another language shall be accompanied by an English translation, in which case, for purposes of interpretation of the bid, the English translation shall govern.

If any supporting documents submitted are in any language other than English, translation of the same in English language is to be duly attested by the Applicant.

Details to be mentioned exactly on sealed envelope

EoI Details

Notice No.: PSCDCL / LPWCN / 29 / 2018 EoI for
“Selection of System Integrator for Design and
Implementation of Low-Power Wireless Communication
Network Infrastructure for Pune Smart City Services”

Last date of Submission: On or before 22/10/2018

To,

CEO,
Pune Smart City
Development Corporation
Limited, Pune

6.8 Evaluation of EoI

All the information provided will be considered for the purpose of inclusion in the RFP to be floated in the later stage. PSCDCL may optionally invite Applicants to make a presentation as part of the evaluation. The feedback received will be evaluated may be considered for designing the actual RFP.

PSCDCL may require verbal/written clarifications from the Applicants to clarify ambiguities and uncertainties arising out of the information submitted.

6.9 Key Suggestions

Workable comments and suggestions on the Scope of Work of this EoI that could overall improve the quality/effectiveness of this project shall be considered by PSCDCL at its own discretion.

6.10 No obligation to issue of RFP

PSCDCL shall be under no obligation to issue a Request for Proposal (RFP) for the Project described in this EoI Document.

6.11 Right to cancel the EoI Process

PSCDCL may cancel this EoI process at any stage without assigning any reasons whatsoever and will not be liable to compensate any Applicant on any grounds

whatsoever. The Applicants shall not be entitled to refund of cost of documents or other costs in case the EoI is cancelled for whatsoever reason or without assigning any reason.

6.12 Proposed Timelines

The proposed timelines to complete the implementation of the project is 6 months and for the O&M phase is 5 years.

Below is the list of proposed deliverables for the SI:

#A	Key Deliverables
1	Project Charter
	Stakeholder responsibility assignment (RACI) matrix
	Mobilization of resources & Inception report
2	Detailed Project Management Plan
	Requirement Gathering Analysis & final FRS report
	Technical system & network architecture design report & final SRS document
	Plan for Supply, Installation and Configuration of devices for Low-Power Wireless Connectivity network solution
3	Supply, installation and configuration of devices for Low-Power Wireless Connectivity network solution
4	Implementation & Unit testing
5	System Integration Testing
6	User Acceptance Testing
7	Training and capacity building for the relevant PSCDCL/PMC officials
8	Final Acceptance Testing
9	Go Live (T1)
10	O&M period

Applicants to furnish their feedback in the concept note regarding the proposed timelines.

7. Specific formats for the Applicants to fill in the details

7.1 Format A_1: Cover Letter

[To be printed on the Applicant company's/ Lead Member's letterhead and signed by its Authorized signatory]

dd/mm/yyyy

To,
The CEO PSCDCL,
2nd Floor, ICC Tower "A",
Senapati Bapat Road,
Pune - 411 016,
(Maharashtra), India

Sub.: Submission towards Expression of Interest ("EoI") for "Selection of System Integrator for Design and Implementation of Low-Power Wireless Communication Network Infrastructure for Pune Smart City Services".

EoI Ref.: [•]

Dear Sir/ Madam,

Having examined the EoI, the receipt of which is hereby duly acknowledged, I/We offer to submit the EoI for the Project.

We agree and understand that this EoI is non-binding and non-committal. PSCDCL or its directors, employees, associates, affiliates or its agents shall not be liable to me/us for any liability arising directly or indirectly from our participation in the EOI Process.

We further agree, understand and fully comprehend that PSCDCL may in its

absolute and exclusive discretion at any time change, alter, replace, remove and/or cancel any or all part of the EoI Document or the Project. PSCDCL may also abandon, call-off, alter, replace, revise the Project. Furthermore, PSCDCL is under no obligation or compulsion in any manner whatsoever to release or publish the RFP, it may also change or replace or cancel any or all part of the bidding process.

We submit hereto my/our EoI as per the requirements and details specified in the EoI Document. I/We confirm that the information contained in these submissions or any part thereof, including the appendices, and other documents and instruments delivered or to be delivered to PSCDCL, are true, accurate, verifiable and complete. These submissions include all information necessary to ensure that the statements therein do not in whole or in part mislead PSCDCL in its EoI Process.

We fully understand and agree to comply that on verification, if any of the information provided here is found to be misleading the EoI Process, I/we are liable to be disqualified from the EoI Process, if selected to do so.

We agree for unconditional acceptance of all the terms and conditions set out in the EoI Document and also agree to abide by this EoI for a period of 120 days from the date of submission.

We agree that you are not bound to accept any EoI you may receive. I/We also agree that you reserve the right in absolute sense to reject all or any of the EoI received as per the EoI Document and Advertisement.

It is hereby confirmed that I/We am/are entitled to act on behalf of my/our firm and empowered to submit this document as well as such other documents, which may be required in this connection.

Signature of Authorized Signatory (with official stamp)

Vide Board Resolution dated / Authority letter dated [•]

Name of Authorised Signatory: [•]

Designation of Authorised Signatory: [•]

Address of the Applicant: [•]

Telephone & Fax of the Applicant: [•]

E-mail address of the Applicant: [•]

7.2 Format A_2: Details of Applicant

[To be printed on the Applicant company's/ Lead Member's letterhead and signed by its Authorized signatory]

To,

The CEO, PSCDCL,

2nd Floor, ICC Tower "A",

Senapati Bapat Road,

Pune - 411 016,

(Maharashtra), India

EoI Ref.: [•]

Dear Sir/ Madam,

Enclosed are the details of Applicant for participation in the EoI for "Selection of System Integrator for Design and Implementation of Low-Power Wireless Communication Network Infrastructure for Pune Smart City Services".

Sr. No.	Particulars	Details
1.	Name of the Applicant/ Lead Member along with all other members of the Consortium	
2.	Type of Firm (Private Limited/ Public Limited company/ LLP/ Partnership/ HUF/ Foreign Incorporated Entity)	
3.	Country of registered Office of the Applicant	
4.	Address of registered office of the Applicant	
5.	Company registration details/number	
6.	Name and permanent address of all directors of the Firm	
7.	Date of incorporation of the Firm	

8.	GST registration number (mandatory for Indian Firms)	
9.	Details of Certificate of CMMI Level 3 / ISO 9000-3 Company or any other equivalent certificate (<i>if any</i>)	
10.	PAN (mandatory for Indian Firms)	
11.	TAN (mandatory for Indian Firms)	
12.	No. of years of operations in India (mandatory for Indian Firms)	
13.	Authorized signatory name	
14.	Authorized signatory designation	
15.	Authorized signatory contact details	

[In case the Applicant is a Consortium then please mention details in the aforesaid details of the Lead Member and all the Consortium Members by making separate tables]

The below mentioned annexures (as applicable) have been attached for the Applicant to further demonstrate that that the Applicant has been operational at least for five (5) years preceding the EoI Due Date:

- a) Certificate of Incorporation/Registration
- b) Memorandum and Articles of Association
- c) Certificate as per Shops & Establishments Act
- d) GST Registration Certificate (mandatory for Indian Firms)
- e) PAN Card (mandatory for Indian Firms)
- f) Consortium Agreement
- g) Partnership Deed/ LL.P. Agreement

In case the Applicant is a Consortium then please enclose all the aforementioned supporting documents of the Lead Member and the Consortium Members.

Yours sincerely,

Signature of Authorized Signatory (with official stamp)

Vide Board Resolution dated / Authority letter dated [•]

Name of Authorised Signatory: [•]

Designation of Authorised Signatory: [•]

Address of the Applicant: [•]

Telephone & Fax of the Applicant: [•]

E-mail address of the Applicant: [•]

7.3 Format A_3: Details of relevant experience

[To be printed on the Applicant company's/ Lead Member's letterhead and signed by its Authorized signatory]

dd/mm/yyyy

To,

The CEO, PSCDCL,
2nd Floor, ICC Tower "A",
Senapati Bapat Road,
Pune - 411 016,
(Maharashtra), India

EoI Ref.: [•]

Dear Sir/ Madam,

We have carefully gone through the requirements and conditions of eligibility specified in the EoI Document for EoI for "Selection of System Integrator for Design and Implementation of Low-Power Wireless Communication Network Infrastructure for Pune Smart City Services".

Description	Details
General Information	
Client for which the project was executed	
Name of the client contact person(s)	
Designation of client contact person(s)	
Contact details of the client contact person(s)	
Project Details	
Date of the Project	
Duration of the project (number of months, start date, completion date, current status)	

Supporting Documents: (Work Order/ Definitive Agreement/ Letter of Award or Letter of Intent)	
---	--

[In case the Applicant is a Consortium then please mention details in the aforesaid details of the Lead Member and all the Consortium Members by making separate tables]

I/We hereby declare that below are the details regarding the Projects that have been taken up and successfully demonstrated by my/our Firm.

I /We further certify that I/We am/are authorized officer in my/our Firm to make this declaration.

Yours sincerely,

Signature of Authorized Signatory (with official stamp)

Vide Board Resolution dated / Authority letter dated [•]

Name of Authorised Signatory: [•]

Designation of Authorised Signatory: [•]

Address of the Applicant: [•]

Telephone & Fax of the Applicant: [•]

E-mail address of the Applicant: [•]

7.4 Format A_4: Concept Note

[To be printed on each company's letterhead and signed by Authorized signatory]

dd/mm/yyyy

To,

The CEO PSCDCL,
2nd Floor, PMC Main Building,
Shivaji Nagar,
Pune - 411 005,
(Maharashtra), India

EoI Ref. No: [•]

Dear Sir/ Madam,

In response to the EoI Document Reference No. [•]/2017 dated [•] for “Selection of System Integrator for Design and Implementation of Low-Power Wireless Communication Network Infrastructure for Pune Smart City Services”, we have prepared a concept note which is attached herewith. The concept note is prepared in good faith, after understanding the EoI document and requirements of PSCDCL.

Name of the Applicant: [•]

Authorized Signatory: [•]

Seal of the Organization: [•]

Business Address: [•]

Date: [•]

Place: [•]

Vide Board Resolution dated [•]

Note: The concept note to be prepared and submitted by the Applicants should include the details listed in Section 4.1 of the EoI Document. Please ensure that all requirements mentioned in the EoI Document with respect to the concept note are to be fully covered.

7.5 Format A_5: Declaration – No Blacklisting

[To be printed on the Applicant company's/ Lead Member's letterhead and signed by its Authorized Signatory]

dd/mm/yyyy

To,
The CEO PSCDCL,
2nd Floor, ICC Tower “A”,
Senapati Bapat Road,
Pune - 411 016,
(Maharashtra), India

EoI Ref. No: [•]

Dear Sir/ Madam,

In response to the EoI Reference No. [•]/2018 dated [•] for EoI for “Selection of System Integrator for Design and Implementation of Low-Power Wireless Communication Network Infrastructure for Pune Smart City Services”, as an owner/ partner/ Director of [•], I/ We hereby declare that presently our firm [•] is having unblemished record and is not declared ineligible for corrupt and fraudulent practices either indefinitely or for a particular period of time by the Pune Municipal Corporation and/or the Government of India and/or any State Government in the last 3 (three) preceding financial years from 2017-18.

I/We further declare that presently our Firm (name of the Firm) is not blacklisted and not declared ineligible for reasons other than corrupt and fraudulent practices by any State/ Central Government/ PSU on the date of Application Submission.

If this declaration is found to be incorrect then without prejudice to any other action my/our application may be rejected and PSCDCL may take any other action that

may deem fit to it.

Yours sincerely,

Signature of Authorized Signatory (with official stamp)

Vide Board Resolution dated / Authority letter dated [•]

Name of Authorised Signatory: [•]

Designation of Authorised Signatory: [•]

Address of the Applicant: [•]

Telephone & Fax of the Applicant: [•]

E-mail address of the Applicant: [•]

7.6 Format A_6: Power of Attorney for Signing the EoI:

[To be printed on Non-Judicial Stamp Paper of INR 500 and duly attested by notary public] [Please Note Stamp Duty payable for Power of Attorney in the State of Maharashtra as per the Maharashtra Stamp Act of 1958 is INR 500] [In case the Applicant is a Consortium, then each Consortium Member shall submit this Power of Attorney authorizing the authorized signatory of the Lead Member to submit the Application and by the Lead Member authorizing the authorized signatory of the Consortium Member to submit the Application]

EoI Ref.: [•]

KNOW ALL MEN BY THESE PRESENTS that the undersigned [name], [title] of [name of the Firm] (hereinafter referred to as the “**Firm**”), is lawfully authorised to represent and act on behalf of the Firm, whose registered address is [Firm’s address], and does hereby appoint [name], [title], of [firm] of [•], whose signature appears below, to be the true and lawful attorney, and authorised the said attorney to sign the EoI, related documents, conduct negotiations, sign any agreement related to the EoI, supporting documents and other documents as required under the EoI Document and other documents as requisitioned by PSCDCL and execute all the necessary matters related thereto, and to do all such acts, deeds, things and matters in the name and on behalf of the Company in connection with the execution thereof, pertaining to the EoI for “Selection of System Integrator for Design and Implementation of Low-Power Wireless Communication Network Infrastructure for Pune Smart City Services”.

We hereby agree to ratify all acts, deeds, and things lawfully done by our said attorney pursuant to this Power of Attorney and that all acts, deeds and things done by our aforesaid attorney shall and always be deemed to have been done by us.

All terms not defined herein, shall derive their meaning in the EoI Document.

IN WITNESS WHEREOF WE THE PRINCIPALS ABOVE NAMED HAVE EXECUTED THIS POWER OF ATTORNEY ON THIS [•] DAY OF [•], 2018

In the presence of

Before

Me

OFFICIAL SEAL AND SIGNATURE OF THE FIRM:

Name of the Legal Representative (*executant*): [•]

Duly authorised by the board to issue such Irrevocable Power of Attorney dated this _____ day of _____ (In case the Firm is a company).

Signature of the Legal Representative:

Name of the Attorney:

In the capacity of:

[Insert title or other appropriate designation]

Signature of the Attorney:

Company's seal:

Witnesses:

1. Name: _____

Address: _____

Signature: _____

2. Name: _____

Address: _____

Signature: _____

Note:

- 1. The Applicant should include such power of attorney in its EoI.*
- 2. The mode of execution of the power of attorney should be in accordance with the procedure, if any, laid down by the Applicable Law.*
- 3. Also, wherever required, the executant(s) should submit for verification the extract of the charter documents and documents such as a board or shareholder's resolution/ power of attorney in favour of the person executing this power of attorney for the delegation of power hereunder on behalf of the executant.*

4. *For a power of attorney executed and issued overseas, the document will also have to be legalised by the Embassy of the Republic of India/ High Commission of the Republic of India/ Consulate General of the Republic of India/ Honorary Consulate General of the Republic of India and notarised in the jurisdiction where the power of attorney is being issued. However, the power of attorney provided by executants from countries that have signed the Hague Legalisation Convention 1961 are not required to be legalised by the Indian embassy if it carries a conforming apostille certificate.*